

# Erbauer®

## Petrol Blower (27.6 cm<sup>3</sup>)

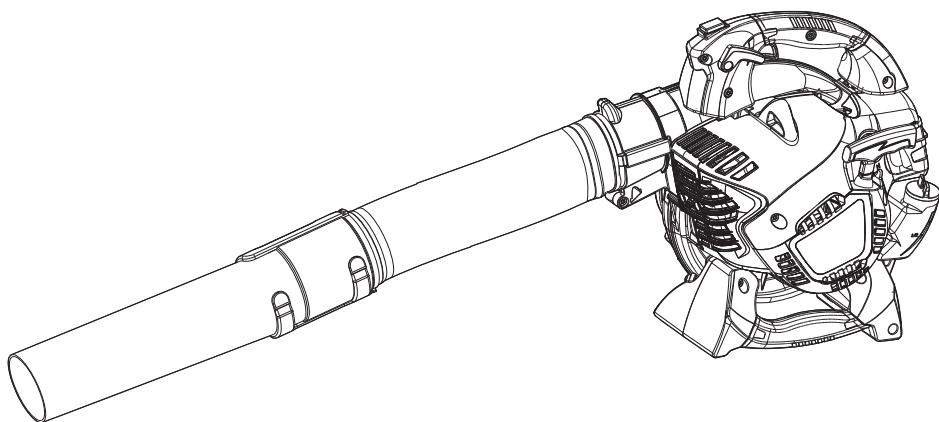

Original Instructions – EBP28\_V10322

### EBP28

EAN: 5059340256375

BX220IM/B3



**WARNING:** Read the instruction handbook thoroughly before using the machine!

# Let's get started...

These instructions are for your safety. Please read through them thoroughly before use and retain them for future reference.



## Getting **Started...** 02

<b>Safety</b> information	03
<b>Your</b> machine	13
<b>Technical</b> specification	15
<b>Before you start</b>	16
<b>Quick start</b>	22



## In more **detail...** 24

<b>Machine</b> functions	24
<b>Operation</b>	25
<b>Care and maintenance</b>	31
<b>Troubleshooting</b>	40
<b>Recycling and disposal</b>	41
<b>Guarantee</b>	42
<b>Customer care and technical helpline</b>	43
<b>Availability of spare parts</b>	44
<b>UK declaration of conformity</b>	45
<b>EU declaration of conformity</b>	46

## Safety warnings

### **IMPORTANT READ CAREFULLY BEFORE USE KEEP FOR FUTURE REFERENCE**

- > This machine is not intended for use by children and persons with reduced physical, sensory or mental capabilities, or lack of experience and knowledge.
- > Children should be supervised to ensure that they do not play with the machine.



**WARNING!** Your safety and the safety of others is very important. Of course, it is not practical or possible to warn you about all the hazards associated with operating or maintaining this machine. At all times you must use your own good judgment.

### **Training**

Read the instructions carefully. Be familiar with the controls and the proper use of the machine.

### **Petrol powered blower safety warnings**

- > Read all instructions carefully. Be familiar with the controls and the proper use of the machine.
- > Never allow children, persons with reduced physical, sensory or mental capabilities or lack of experience and knowledge or people unfamiliar with these instructions to use the machine. Local regulations can restrict the age of the operator.
- > Keep children, other bystanders and pets away from the machine while operating.
- > The operator or user is responsible for accidents or hazards occurring to other people or their property.
- > While operating the machine always wear substantial footwear and long trousers. Do not operate the machine when barefoot or wearing open sandals. Avoid wearing clothing that is loose fitting or that has hanging cords or ties.
- > Do not wear loose clothing or jewellery that can be drawn into the air inlet. Keep long hair away from the air inlets.
- > Operate the machine in a recommended position and only on a firm, level surface.
- > Do not operate the machine on a paved or gravel surface where ejected material could cause injury.
- > Before using, always visually inspect to see that the fasteners are secure and the housing is undamaged. Replace worn or damaged components in sets to preserve balance. Replace damaged or unreadable labels.
- > Running this machine in a confined or badly ventilated area can result in death due to asphyxiation or carbon monoxide poisoning. The machine is for outdoor use only.

- > Take extreme care in wet and freezing weather conditions. Do not work in rain, windy or stormy weather.
- > Wear a dust mask. The use of this machine can generate exhaust gases, lubrication oil mist and dust containing chemicals known to cause respiratory damage.
- > Wear slip-resistant footwear, snug-fitting clothing, protective gloves, eye or face and hearing personal protective equipment (PPE).
- > The machine is extremely noisy when in use. Wear hearing protection at all times while operating the machine.
- > Always visually check the machine before use.
- > Do not attempt to tackle any job that you are not adequately trained for.
- > Do not operate the machine if it has faulty safety equipment or damaged parts.
- > Do not under any circumstances modify the machine. Modifications can result in serious personal injury or death.
- > All machine servicing and maintenance, other than the items listed in this manual, should be performed by an authorised service centre.
- > First time user should have practical instruction in the use of the machine and protective equipment from an experienced operator.
- > National regulation can restrict the use of the machine.

### **Clothing and personal protective equipment (PPE)**

- > Secure long hair so that they are above the shoulder level.
- > Do not wear loose fitting clothing or jewellery as those could be drawn into the engine or blower outlet.
- > Use the following safety clothing and personal protective equipment (PPE) when operating the machine:
  - Wear hearing/ear protection (compliant to EN 352-1)
  - Wear eye protection (compliant to EN 166)
  - Wear face protection (compliant to EN 166)
  - Wear protective gloves (compliant to EN ISO 21420 Class 0)
  - Wear safety steel toe capped footwear (complaint to EN ISO 20345 Class 2)
  - Wear protective leggings (compliant to EN ISO 11393-2, EN ISO 13688 Class 1)
  - Wear dust mask
  - First aid kit in case of injury
  - Dry powder fire extinguisher readily available

## Fuel handling

- > Always switch the machine off, disconnect the spark plug connector and let the machine cool down before refuelling it.
- > Fuel vapour pressure may build up inside the fuel tank depending on the fuel used, weather conditions and the tank venting system. To reduce the risk of burns and other personal injuries, remove the fuel tank cap carefully to allow any pressure build up to release slowly.
- > Fuel and fuel vapour are highly flammable. Take care when handling fuel.
- > Be aware of fire risks, explosion and inhalation risks.
- > Do not smoke while operating the machine, handling fuel or near fuel.
- > Ensure the spark plug connector is secure. Loose connector may cause electrical arcing that could ignite combustible fumes and cause a fire or explosion.
- > Always use suitable aids such as funnels and filler necks. Do not spill any fuel on the machine or its exhaust system. There is a risk of ignition. Remove spilled fuel carefully from all parts of the machine. Any residue which may be present must have completely volatilised, before the machine is put into operation!
- > Never refuel indoors.
- > Never use the machine in environments where there is a risk of explosion. Exhaust gases and fuel fumes are noxious. Fuel fumes can ignite.
- > Avoid skin contact with petrol.
- > Do not eat or drink, while you are refuelling the machine. If you have swallowed petrol or oil, or if petrol or oil has got into your eyes, then seek the advice of a doctor immediately.
- > Check regularly for leaks from the fuel tank cap, oil tank cap and fuel lines.
- > Use caution when handling fuel. To avoid any accidental fires, move the machine at least 3 metres from the fuelling point before starting the engine.
- > Tighten the fuel tank cap thoroughly after refilling the fuel tank.
- > Do not operate the machine if it is leaking fuel.
- > Do not remove the fuel tank cap while the engine is running.
- > Do not store cans of fuel or refill the fuel tank in any place where there is a boiler, stove, wood fire, electrical sparks, welding sparks, or other sources of heat or fire which might ignite the fuel.
- > If any fuel spillage occurs during refuelling, use a dry rag to wipe up spills and allow remaining fuel to evaporate before starting the engine on again.
- > If you have spilt fuel on yourself or on your clothes, change your clothes and wash any part of your body that has come in contact with fuel before turning the engine on again.
- > If fuel has ignited, put out the fire with a dry powder fire extinguisher.

## Getting started

- > Do not operate the machine indoors. The machine produces poisonous exhaust fumes whilst the engine is running which may be colourless and odourless.
- > Do not wrap the recoil starter rope around your hand whilst starting the machine. This may result in injuries to your hand or fingers.
- > Always hold the machine by the main handle (5) with the right hand. Keep handles dry, clean and free from oil and grease. Greasy, oily handles are slippery and may cause loss of control.
- > To reduce the risk of stumbling and loss of control, do not walk backward while operating the machine.
- > Stop the engine and wait until the moving parts come to a complete stop before placing the machine down.
- > Check for signs of wear or damage before each use, after any impact or if the machine has been dropped. Repair the machine if necessary.

## Operation

- > Before starting the machine, make certain that the tube and nozzles are empty.
- > Keep your face and body away from the blower outlet.
- > Do not allow hands or any other part of the body or clothing inside the tube or nozzles, or near any moving part.
- > Keep proper balance and footing at all times. Do not overreach. Never stand at a higher level than the base of the machine when feeding material into it.
- > Always stand clear of the discharge zone when operating this machine.
- > Do not touch moving hazardous parts before they have come to a complete stop.
- > Do not operate the machine near open windows or doors.
- > Do not blow hard objects such as nails, bolts and rocks.
- > Apply extra care when cleaning debris from stairs or other tight areas.
- > Keep all parts of your body away from the blower outlet. Do not remove blockages or jams when the machine is switched on. Stop the engine and wait until the moving parts come to a complete stop when clearing jammed material. One moment of inattentiveness while operating the machine may result in serious personal injury.
- > Carry the machine by the handles with the engine off. Handling the machine properly reduces the possibility of personal injury.
- > Never operate the machine on a ladder or other insecure support. Do not work above shoulder height.
- > If the machine starts to vibrate abnormally, check it immediately. Excessive vibration can cause injury.
- > Always ensure the machine is fully assembled before using it. Never attempt to use an incomplete machine or one fitted with an unauthorised modification.
- > Do not operate the machine if you are tired or ill.
- > Do not operate the machine under the influence of drugs, alcohol or medication.
- > Use rakes and brooms to loosen debris before blowing.

- > Operate the machine only in daylight or in good artificial light.
- > Slightly dampen surfaces in dusty conditions.
- > Operate the machine only at reasonable hours – not early in the morning or late at night when people might be disturbed.
- > Make sure that the air vents are kept clear of debris.
- > Make sure that the air intake of the combustion engine is clear. Keep the air intake free of dust, dirt particles, gases and fumes.
- > Never use the machine without the air filter installed.
- > Check for signs of wear or damage before each use, after any impact or if the machine has been dropped. Repair the machine if necessary.
- > Stop the engine, disconnect the spark plug connector:
  - before clearing blockages;
  - before cleaning or servicing the machine;
  - if the machine starts to vibrate abnormally (check immediately);
  - whenever you leave the machine unattended;
  - before refuelling.
- > Do not operate the machine if you have any medical conditions that might be aggravated by strenuous work. Consult a doctor before operating this machine.
- > Do not touch the exhaust during use - IT GETS VERY HOT during use.
- > Do not operate the machine near or around flammable liquids or gases.
- > Do not grip the handle with constant or excessive pressure. This might increase the feeling of vibration and the risk of “Vibration White Finger (VWF)” disease. To minimize vibration exposure, use the lock-on lever to lock the throttle trigger for continuous operation.

### Transport and storage

- > Stop the engine and let the engine come to a complete stop before transporting the machine.
- > Carry the machine with the engine stopped the blower outlet away from the body.
- > Allow the engine to cool before storing in any enclosure.
- > Secure the machine when transporting in a vehicle to prevent turnover, fuel spillage and damage to the machine. Use line or ratchet tie-down if necessary.
- > Store the machine and fuel so that there is no risk of leakages or fumes coming into contact with sparks or naked flames from electrical equipment, electric engines, relays/switches, boilers etc.
- > For longer periods of storage or transportation the fuel and tanks must be emptied. Dispose of waste oil and fuel at a local petrol station, local authority centre or where facilities exist.
- > Store fuel and oil in an approved container specifically designed for that purpose.
- > Clean the machine and have it serviced before any long-term storage.

### Vibration and noise reduction

To reduce the impact of noise and vibration emission, limit the time of operation, use low-vibration and low-noise operating modes as well as wear personal protective equipment.

Take the following points into account to minimise the vibration and noise exposure risks:

- > Only use the machine as intended by its design and these instructions.
- > Ensure that the machine is in good condition and well maintained.
- > Use correct attachments for the machine and ensure they in good condition.
- > Keep a tight grip on the handles/gripping surfaces.
- > Maintain this machine in accordance with these instructions and keep it well lubricated (where appropriate).
- > Plan your work schedule to spread any high vibration tool use across a longer period of time.

### Emergency

**Familiarise yourself with the use of this machine by means of this instruction manual. Memorise the safety directions and follow them to the letter. This will help to prevent risks and hazards.**

- > **Always be alert when using this machine, so that you can recognise and handle risks early.** Fast intervention can prevent serious injury and damage to property.
- > **Stop the engine and disconnect the spark plug connector if there are malfunctions.** Have the machine checked by a qualified professional and repaired, if necessary, before you operate it again.
- > **In case of fire stop the engine and disconnect the spark plug connector.** Take fire-extinguishing measures immediately if the machine switch is no longer accessible.



**WARNING!** Never use water to extinguish the machine on fire. Burning fuel must be extinguished with special extinguishing agents! We recommend that you keep a suitable fire extinguisher within reach in your work area! We recommend to have dry powder fire extinguisher always available.



## Residual risks

**Even if you are operating this machine in accordance with all the safety requirements, potential risks of injury and damage remain. The following dangers can arise in connection with the structure and design of this machine:**

- > Health defects resulting from vibration emission if the machine is used over long periods of time or not adequately managed and properly maintained.
- > Injuries and damage to property due to broken application tools or the sudden impact of hidden objects during use.
- > Danger of injury and property damage caused by flying objects.
- > Burns, if touching hot surfaces.





**WARNING!** This machine produces an electromagnetic field during operation! This field may under some circumstances interfere with active or passive medical implants! To reduce the risk of serious or fatal injury, we recommend persons with medical implants to consult their doctor and the medical implant manufacturer before operating this machine!

## Symbols

On the machine, the rating label and within these instructions you will find among others the following symbols and abbreviations. Familiarise yourself with them to reduce hazards like personal injuries and damage to property.

kW	Kilowatt	l	Litre
cm <sup>3</sup>	Cubic centimetre	ml	Millilitre
/min or min <sup>-1</sup>	Per minute	°C	Degree Celsius
mm	Millimetre	dB(A)	Decibel (A-rated)
cm	Centimetre	m/s <sup>2</sup>	Metres per second squared
kg	Kilogram	g/kWh	Gram per kilowatt per hour
kg/h	Kilogram per hour	m/s	Metres per second
yyWxx	Manufacturing date code; year of manufacturing (20yy) and week of manufacturing (Wxx)		

### Description of signal words:

-  **DANGER!** The signal word that indicates a hazard with a high level of risk which, if not avoided, will result in death or serious injury.
-  **WARNING!** The signal word that indicates a hazard with a medium level of risk which, if not avoided, could result in death or serious injury.
-  **CAUTION!** The signal word that indicates a hazard with a low level of risk which, if not avoided, could result in minor or moderate injury.
- NOTE!** Indicates a practical tip, advice or practice not related to personal injury.



Caution/Warning.  
Read the instruction  
manual.



Note/Remark.



Wear eye protection (compliant to EN 166).



Wear hearing/ear protection (compliant to EN 352-1).



Wear face shield (compliant to EN 166).



Wear safety steel toe capped footwear (compliant to EN ISO 20345 Class 2).



Wear protective gloves (compliant to EN ISO 21420 Class 0).



Do not expose the machine to rain or wet conditions.



Open flames in the work area, around the machine and in the vicinity of flammable materials are prohibited!



Do not smoke in the work area, around the machine and in the vicinity of flammable materials!



Risk of fire/flamable materials.



Hot surface, do not touch! High temperatures on the machine's surfaces and structural parts that could cause burns, if they are touched. The machine can also stay hot for a longer period of time after the operation!



Petrol engines produce toxic carbon monoxide exhaust fumes. Breathing carbon monoxide can cause nausea, fainting or even death. Do not operate the engine indoors!



Keep hands out of the openings while the machine is running.



Objects thrown by the machine could hit the operator or other bystanders. Always ensure that other people and pets remain at a safe distance from the machine when it is in operation. In general, children must not come near the area where the machine is operating.



Stop the engine before refuelling. Never refuel the machine while the engine is running.

40:1

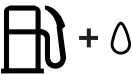

Only refuel unleaded petrol and oil mixture in ratio 40:1. Do not use any other mixture ratio.



Stop the engine and disconnect the spark plug connector before assembly, cleaning, adjustments, maintenance, storage and transportation.

H

High-speed mixture adjuster for adjusting fuel delivery at full throttle.

L

Low-speed mixture adjuster for adjusting fuel delivery at idling speed.



Choke – CLOSED position.



Choke – OPEN position.



Engine manual start; recoil starter.



Guaranteed sound power level value in dB.



The machine complies with the applicable European directives and an evaluation method of conformity for these directives was done.



The machine complies with the conformity requirements of the applicable UK regulations.

EBP28

Designation of the tool  
(**E**\_Brand Name; **BP**\_Petrol Blower; **28**\_Engine size in cc)



1E35F

Engine brand logo, Family-Type and model number



SHA1/P V-0012 EU type-approval for the engine

## Your machine

### Main unit

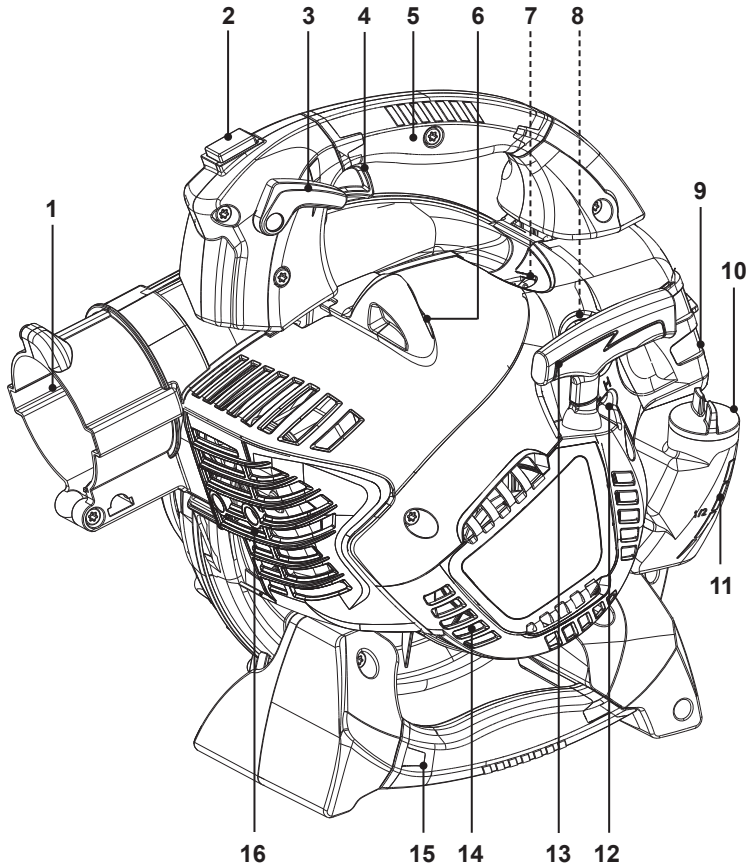

- |  |   |
|--|---|
| 1. Blower outlet                           | 9. Air filter case                          |
| 2. Ignition switch (I / O)                 | 10. Fuel tank cap                           |
| 3. Lock-on lever (throttle locking device) | 11. Fuel tank                               |
| 4. Throttle trigger                        | 12. Adjusting screws for carburetor (H / L) |
| 5. Main handle                             | 13. Recoil starter handle                   |
| 6. Spark plug connector                    | 14. Air vents                               |
| 7. Primer                                  | 15. Auxiliary handle                        |
| 8. Choke                                   | 16. Exhaust                                 |

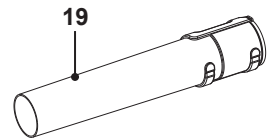
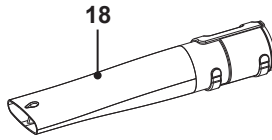
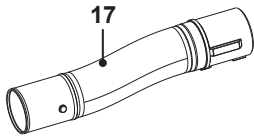
**Blower assembly**

17. S-shaped tube  
18. Flat nozzle

19. Round nozzle

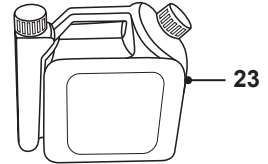
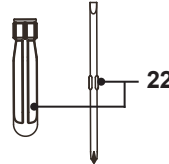
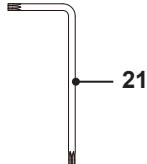
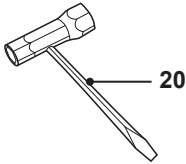
**Accessories**

20. Multi-tool  
21. Torx key

22. Screwdriver  
23. Fuel mixing bottle

## Technical specifications

### General

- > **Dimensions (without tubes):** approx. 35 x 25 x 35 cm
- > **Weight:** approx. 4.7 kg
- > **Fuel tank capacity:** 400 ml
- > **Petrol type:** **Octane rating of at least 90, unleaded, Maximum 10% renewable ethanol (E10 or below)**
- > **Engine oil type:** **Top quality synthetic oil specifically for two-stroke engines, of JASO FC minimum specification.**
- > **Fuel-oil ratio:** 40:1
- > **Specific fuel consumption at maximum engine power:** 550 g/kWh
- > **Fuel consumption at maximum engine power:** 0.44 kg/h

### Engine

- > **Engine model:** 1E35F
- > **Engine type:** Air cooled, 2-stroke engine
- > **Engine displacement:** 27.6 cm<sup>3</sup>
- > **Maximum engine power:** 0.8 kW
- > **Maximum operating engine speed:** 8300 min<sup>-1</sup>
- > **Maximum air velocity:** 83 m/s
- > **Spark plug type:** NGK BPMR7A
- > **Spark plug gap:** **0.6-0.7 mm**

### Sound emission level

- > **Sound pressure level at operator position:** 93.9 dB(A)
- > **Uncertainty K:** 3 dB(A)
- > **Measured sound power level  $L_{WA}$ :** 106.6 dB(A)
- > **Uncertainty K:** 3.0 dB(A)
- > **Guaranteed sound power level  $L_{WA}$ :** 109 dB(A)

### Vibration emission level

- > **Hand-arm vibration  $a_{hw}$ :** 2.06 m/s<sup>2</sup>
- > **Uncertainty K:** 1.5 m/s<sup>2</sup>

The sound values have been determined according to noise test code given in EN 15503, using the basic standards EN ISO 3744 and EN ISO 11201.

Wear ear protection, especially when sound pressure is over 70 dB(A).

The declared vibration value has been measured in accordance with a standard test method (according to EN 15503) and may be used for comparing one machine with another. The declared vibration value may also be used to evaluate the exposure for the user caused by vibration in advance.



**WARNING!** Depending on the actual use of the machine the vibration values can differ from the declared total. Adopt proper measures to protect yourself against vibration exposures. Take the whole work process including times the machine is running under no load or switched off into consideration! Proper measures include among others regular maintenance and care of the machine and accessories, keeping hands warm, periodical breaks and proper planning of work processes!

## Unpacking

1. Unpack all parts and lay them on a flat, stable surface.
2. Remove all packing materials and protective shipping materials, if applicable.
3. Make sure the delivery contents are complete and free of any damage. If you find that parts are missing or show damage do not use the machine and contact your dealer. Using an incomplete or damaged machine represents a hazard to operators and property.
4. Ensure that you have all the accessories and tools needed for assembly and operation. This also includes suitable personal protective equipment.



**WARNING!** The machine and the packaging are not children's toys! Children must not play with plastic bags, sheets and small parts! There is a danger of choking and suffocation!



## You will need

### (items not supplied)

- > Suitable personal protective equipment
- > Fuel funnel with filter
- > Suitable 2-stroke engine oil for air-cooled engines, high quality
- > Suitable fuel (unleaded petrol)
- > Container to collect fuel
- > First aid kit
- > Dry powder fire extinguisher readily available
- > Soft absorbent cloth (for fuel spills)

### (items supplied)

- > Multi-tool (20)
- > Torx key (21)
- > Screwdriver (22)
- > Fuel mixing bottle (23)

## Assembly



**WARNING!** The machine must be fully assembled before operation!



Do not use a machine that is only partly assembled or assembled with damaged parts!

Follow the assembly instructions step-by-step and use the pictures provided as a visual guide to assemble the machine easily!

Disconnect the spark plug connector before assembly! Reconnect it after assembly (see "Maintenance").



**NOTE:** Take care of small parts that are removed during assembly or when making adjustments. Keep them secure to avoid loss. Complete the assembly on a flat and stable surface.

## Blower assembly

1. Select the flat nozzle (18) or round nozzle (19) for the desired application.



**NOTE:** Flat nozzle (18) offers higher air speed for more demanding tasks and for heavier debris. Round nozzle (19) offers greater air volume for general blowing tasks in a larger area and for lightweight debris.

2. Align the slot of nozzle (18/ 19) with the pin on the S-shaped tube (17). Insert the S-shaped tube (17) into the nozzle (18/ 19) (Step 1, Fig.1). Turn the S-shaped tube (17) clockwise until the pin reaches end of the slot (Step 2, Fig. 1).

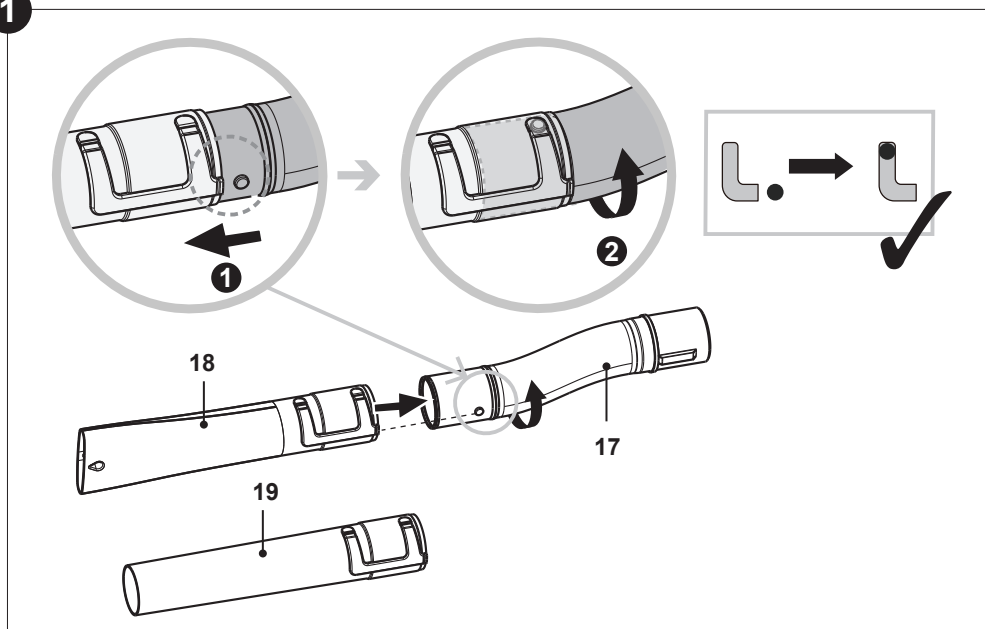
**1**

3. Align the tabs on the other end of the S-shaped tube (17) with the slots on the blower outlet (1). Insert the S-shaped tube (17) into the blower outlet (1) all the way until it clicks into place (Fig. 2).

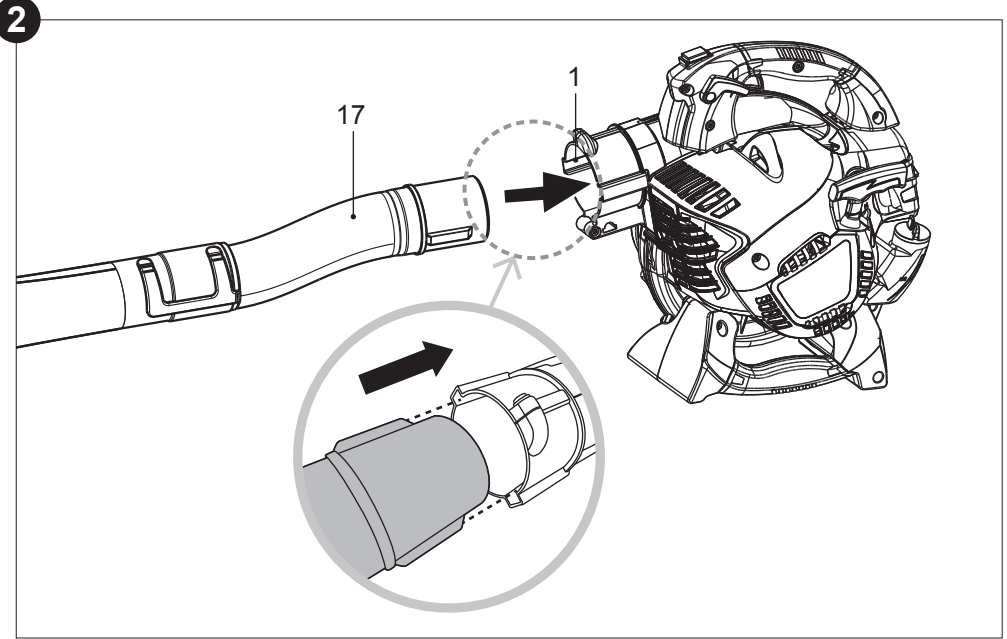

**NOTE:** To detach the S-shaped tube (17) from the blower outlet (1), use the multi-tool (20) to depress the red locking lever, and pull the S-shape tube (17) (Fig. 3).

3



Locking lever

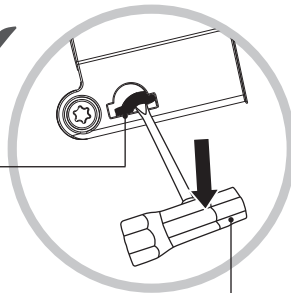

20

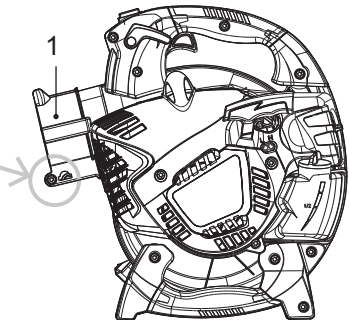

## Filling up fuel and oil



**WARNING!** This machine is not supplied with petrol-oil mixture in the engine! Before operating this machine it is essential to fill it with petrol-oil mixture!

This machine is equipped with a 2-stroke engine, the fuel and oil tank are combined and it is essential to fill a fuel-oil mixture before operating this machine. Observe the technical specifications for suitable fuel and engine oil.







**WARNING!** Fuel and oil are highly inflammable! Fumes will explode if lit! Ensure that there are no naked flames around the machine! Do not smoke while filling fuel and oil!



**NOTE:** To avoid spillage and to filter out debris, use a funnel with filter to fill the fuel mixing bottle (23) and the fuel tank (11).

1. Place the machine on a stable, level surface with the fuel tank cap (10) facing upwards. We recommend laying a non-flammable sheet under the machine.
2. Pour a regular-grade unleaded petrol and a quality engine oil for air cooled 2-stroke engines in the supplied fuel mixing bottle (23) respectively via the 2 openings. Use the scale markings on different sides for your desired ratio for petrol:oil. For example, fill petrol to scale marking "10" first, and then fill 2-stroke oil to scale marking "10". This indicates a correct ratio of 40:1 when using the scale 40:1.

				
100 ml	+	2.5 ml	=	40:1
200 ml	+	5 ml	=	
300 ml	+	7.5 ml	=	
400 ml	+	10 ml	=	

3. Tilt and shake the fuel mixing bottle (23) thoroughly to make the fuel.



**NOTE: Risk of machine damage!**

Never mix fuel and oil directly in the tank of the machine.

Use an anti-oxidant added quality oil expressly labelled for air-cooled 2 stroke engine use (JASO FC GRADE OIL or ISO EGC GRADE). Do not use BIA or TWC (2 stroke water-cooling type) mixed oil. The recommended mixing ratio for petrol:oil is 40:1, which means the mixture consisting of 40 parts petrol and 1 part oil.

4. Unscrew and remove the fuel tank cap (10). Use the multi-tool (20) to unscrew or tighten the cap if necessary (Fig. 4).

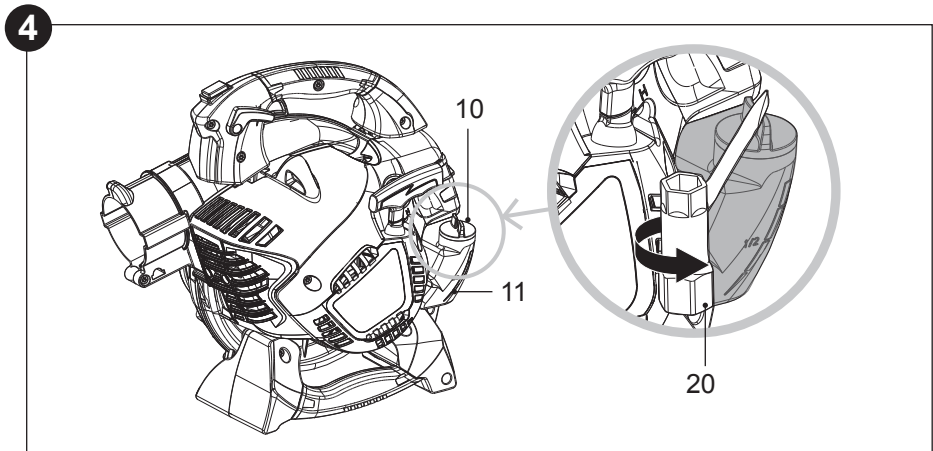

5. Fill the fuel into the fuel tank (11). Leave approximately 5 mm of space between the top of the fuel and the inside edge of the tank to allow for expansion (Fig. 5). Do not overfill.

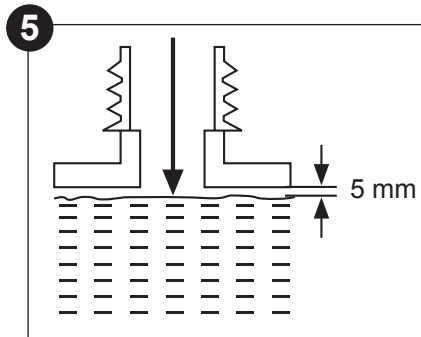

6. Wipe up spilled fuel with a soft cloth. Refit and screw the fuel tank cap (10) firmly (Fig. 4).



**NOTE:** Fuel and oil deteriorate over time. It may be difficult to start the engine if you use fuel which has been kept for more than 30 days. Towards the end of the season, it is advisable to put only as much fuel in the tank as you need for each use, since it should be completely used up before storing the machine. Empty remaining fuel from the tank when storing the machine for over 30 days.

## Operating controls

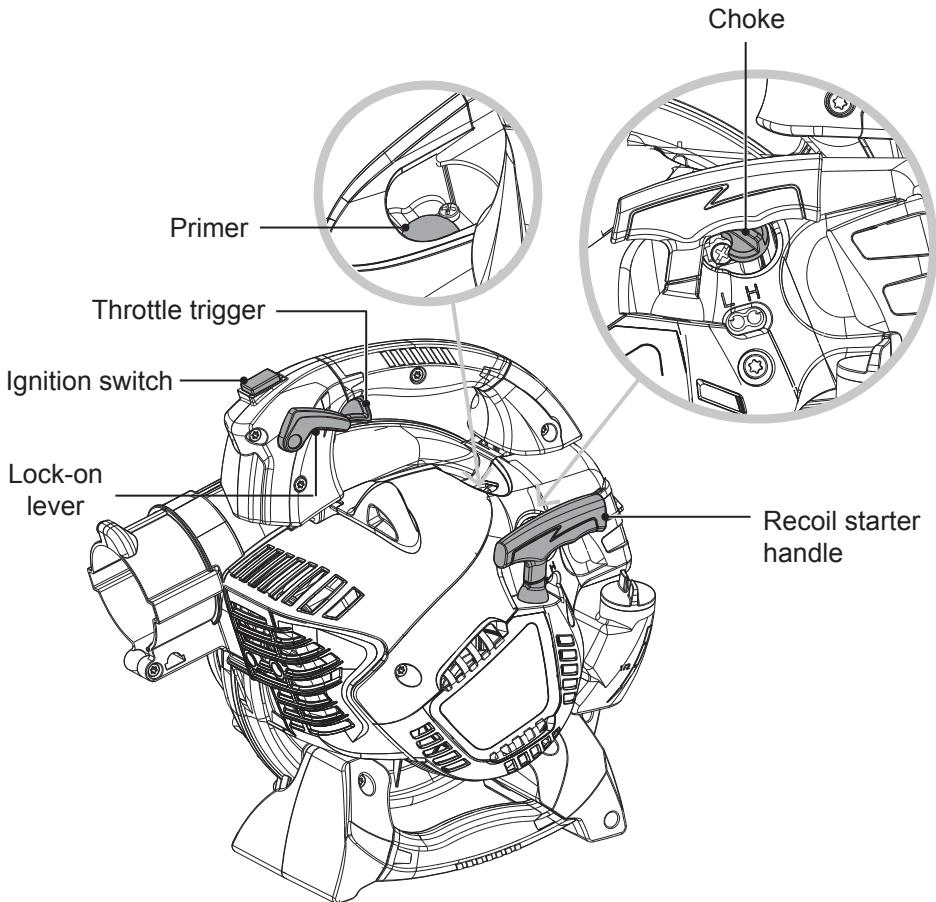

## Preparation



Assemble



Adjust



Add fuel and oil mixture

## Starting

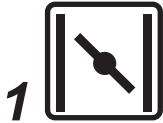

1 Set the choke to  
CLOSE position

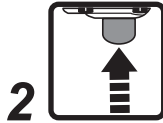

2 Press primer  
**6 times**



3 Pull recoil starter  
handle less than  
5 times

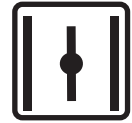

4 Set the choke to  
OPEN position



5 Pull recoil starter  
handle until engine  
starts



6 Slowly squeeze the  
throttle trigger



7 Warm up for  
1- 2 minutes



8 Operate

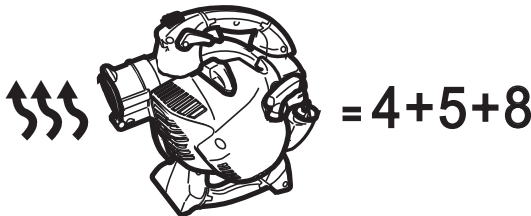

If the engine is warm skip steps 1, 2, 3, 6 and 7.

## Stopping



1 Release throttle trigger



2 Push the ignition switch to **O** position

## Storage



Empty fuel tank



Empty oil



Clean and maintain



Store



**WARNING!** This quick start provides only a short overview of how to start and stop the engine! For safe use it is essential to read the entire instruction manual before first use!

## Intended use

This petrol blower EBP28 is designated with an engine displacement of 27.6 cm<sup>3</sup>. The machine is intended for blowing light debris including leaves, grass and other garden refuse.

The machine is not intended to be use in wet location. Do not use the machine on wet lawns, grass areas or fields.



**WARNING!** The machine must be used by an experienced operator\* having read and understood the safety requirements provided within this instruction manual using appropriate personal protective equipment (PPE)!

\* A trained operator is a person who has the competence and knowledge in the use and hazards associated with using the machine as well as the precautions to be taken to limit these hazards.



## Operation

### Ignition switch

Use the ignition switch (2) to start and stop the engine.

- > **I** position: The engine can start and run.
- > **O** position: The engine stops. After pushing the ignition switch (2) to the **O** position, the ignition switch (2) automatically returns to the **I** position.

### Check before starting:

- > Check the machine, as well as accessories for damage before each use. Do not use the machine if it is damaged or shows wear.
- > Verify that the S-shaped tube (17) and the nozzle (18/ 19) are properly assembled to the blower outlet (1).
- > Check the fuel level, refill if necessary.
- > Always hold the machine by the main handle (5) with the right hand.
- > Ensure that the air vents (14) and exhaust (16) are always unobstructed and clear. Clean them if necessary with a soft brush. Blocked air vents (14) or exhaust (16) may lead to overheating and damage the machine.
- > Stop the engine immediately if you are disturbed while working by other people entering the working area. Always let the machine come to complete stop before putting it down.
- > Do not overwork yourself. Take regular breaks to ensure you can concentrate on the work and have full control over the machine.
- > Use rakes and brooms to loosen debris before blowing.
- > Slightly dampen surfaces in dusty conditions.



**NOTE:** In some countries regulations define at what time of the day and on what special days machines are allowed to be used and what restrictions apply! Ask your community for detailed information and observe the regulations in order to preserve a peaceful neighbourhood and avoid committing administrative offenses!

## Starting the engine



### DANGER! Risk of fire!

- > Due to any spilled fuel, the machine can catch fire.
- > Wipe any spilled fuel up before starting.
- > Start the engine a few metres away from the place where you have filled it.



### NOTE: Risk of machine damage!

Never twist the starter cord around your hand! Only pull on the handle!

Do not suddenly release the recoil starter handle! Allow the rope to return slowly and in a controlled manner each time it is pulled!

### Engine cold start

1. Set the choke (8) the CLOSE  position (Fig. 6).
2. Press the primer (7) until the bubble is filled with fuel (**6 times**) (Fig. 7).

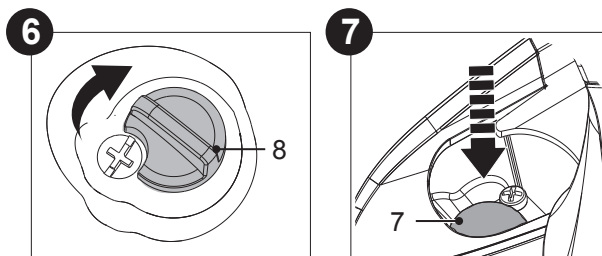

3. Hold the machine securely to the ground. Place your right hand on the main handle (5) and additionally secure the machine at the auxiliary handle (15) with your right foot (Fig. 8).

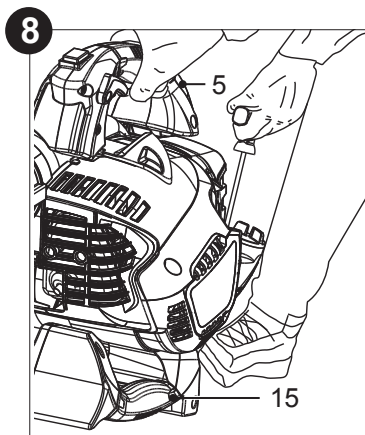

4. Pull the recoil starter handle (13) slowly with your left hand until you feel a definite resistance and then give it a brisk, strong pull. Repeat until the engine attempts to start but no more than 4 times.
5. Set the choke (8) the OPEN |↑| position (Fig. 9).

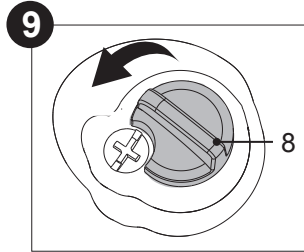

6. Pull the recoil starter handle (13) slowly with your left hand until you feel a definite resistance and then give it a brisk, strong pull. Repeat until the engine starts.
7. Slowly squeeze the throttle trigger (4) to accelerate the engine (Fig. 10). Let the engine warm up for 1-2 minutes. If the engine stops, repeat above steps.

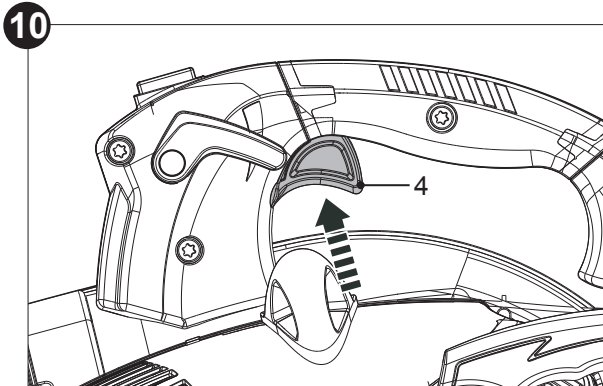

### Engine warm start

1. Set the choke (8) the OPEN  $\downarrow\downarrow$  position (Fig. 11).

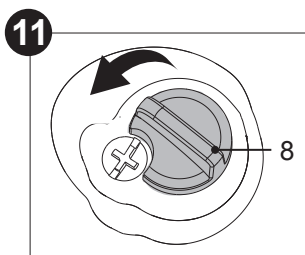

2. Pull the recoil starter handle (13) slowly with your left hand until you feel a definite resistance and then give it a brisk, strong pull. Repeat until the engine starts.



**NOTE:** The machine can be operated with only one hand in blowing mode. Always hold the main handle (5) with the right hand.

### After starting the engine

1. Slowly press down on the throttle trigger (4) to increase the engine speed.
2. For continuous operation, turn the lock-on lever (3) upwards to hold the throttle trigger (4) down (Fig. 12).



**NOTE:** The machine can be operated with only one hand in blowing mode. Always hold the main handle (5) with the right hand.

12

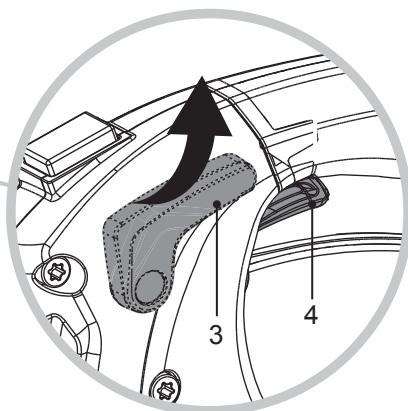
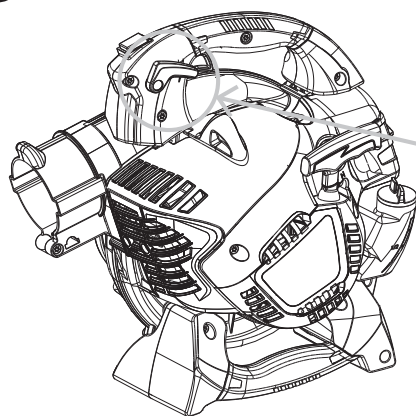

3. Check if the fan stops rotating when you release the throttle trigger (4).

### Stopping the engine

1. Release the throttle trigger (4) and let the machine run in idle for a while.
2. Push the ignition switch (2) to **O** position until engine stops.



**WARNING!** The machine continues to work for some time even after the engine has been stopped! Wait until it comes to a complete stop before you put the machine down!

## Basic operating



**WARNING!** Always wear ear protection, eye protection or face shield to avoid serious personal injury. Do not point the nozzle (18/ 19) in the direction of people or pets.



**WARNING!** Always push the ignition switch (2) to **O** position and let the engine come to a complete stop before placing the machine down.



**NOTE:** Do not block the tube or nozzles to avoid engine damage due to over-revving.



- > Walk through the working area and remove any limbs, rocks or other debris that could become projectiles.
- > Before operation, close car and home windows and doors.
- > Operate the machine at lowest possible throttle to reduce noise and save fuel.

### Using the throttle trigger

- > Squeeze the throttle trigger (4) to start the operation. The speed is controlled by how far the throttle trigger (4) is depressed (Fig. 13).

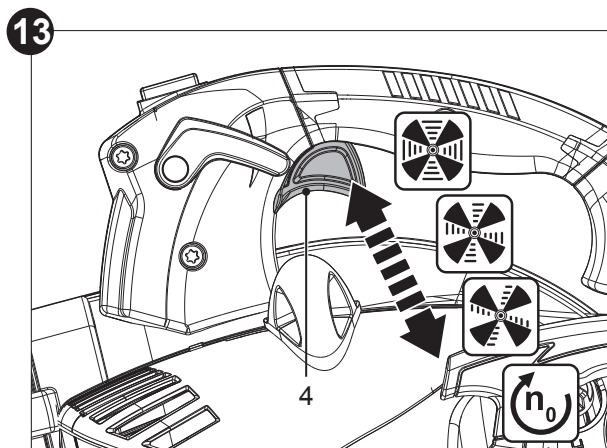

**NOTE:** For continuous operation, turn the lock-on lever (3) upwards to hold the throttle trigger (4) down.

### Blowing mode



- > Operate the machine towards the wind direction instead of against it.
- > Practice controlling the air velocity to lift leaves without stirring up dust.
- > Be aware of the ricochet effect when blowing around objects.
- > Always blow in one direction to avoid blowing debris into an area which has been cleared.



**NOTE:** Use the flat nozzle (18) for more demanding tasks and for heavier debris with a higher air speed. Use the round nozzle (19) for general blowing tasks in a larger area and for lightweight debris with greater air volume.



**NOTE:** The machine can be controlled with one hand. Always grip the machine with the right hand on the main handle (5) during operation.

- > Assemble the S-shaped tube (17) and the nozzle (18/ 19) properly to the blower outlet (1) as described in chapter “Blower assembly”.
- > Hold the nozzle (18/ 19) approximately 10 cm above the ground.
- > Use a sweeping motion from side to side and walk slowly forward (Fig. 14).

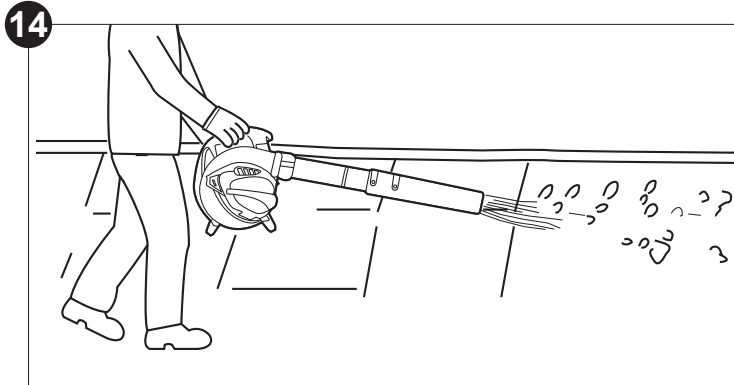

## After use

1. Stop the engine, disconnect the spark plug connector (6). Let the engine come to a complete stop and wait until it cools down.
2. Check, clean and store the machine as described in section “**The golden rules for care**”.

## The golden rules for care



**WARNING!** Always stop the engine, disconnect the spark plug connector and let the machine cool before performing inspection, maintenance and cleaning work.



**DANGER!** Proper maintenance is essential for safe and trouble free operation. Improper maintenance, or failure to address a problem instantly can cause a malfunction which can result in serious injury or even death.

- > Keep the machine clean and clear blockages in the S-shaped tube (17) and nozzles (18, 19).
- > Regular and proper cleaning helps to ensure safe operation and prolongs the life of the machine.

- > Inspect the machine before each use for worn and damaged parts. Do not operate it if you find broken and worn parts. Replace worn parts as necessary or contact an authorised service centre for repair before using the machine again.



**WARNING!** Only perform repairs and maintenance work according to these instructions! All further works must be performed by a qualified specialist!

## Cleaning



**NOTE:** Do not use chemical, alkaline, abrasive or other aggressive detergents or disinfectants to clean this machine as they might be harmful to its surfaces.

### Cleaning the housing

- > Use a damp, lint-free cloth to clean the housing of the machine.
- > Do not immerse the machine into water or any liquids.
- > Clean the ventilation slots on the bottom and at the side cover of the engine with a soft brush. Clogged ventilation slots might cause the engine to overheat.
- > Wipe the surface with a dry cloth afterwards.

### Removing blockages



**WARNING!** Wear safety gloves when removing blockages! Use proper tools to remove debris, e. g. a wooden stick! Never use bare hands!

Ensure the engine is off by setting the ignition switch to **O** position, before removing any nozzles or tube for any maintenance or for removing blockage.

1. Place the machine on an even surface. Detach the S-shaped tube (17) from the blower outlet (1) by depressing the red locking lever with the multi-tool (20) (Fig. 3).
2. Check the tube and nozzles for blockages. Carefully tap the tube or nozzles to loosen the blockage.
3. Check the air vents (14), exhaust (16) and blower outlet (1) for blockages. Remove them with a suitable damp cloth or wooden stick if required.



### Air filter

Inspect the air filter regularly. Clean or replace it with a new one if necessary.

1. Loosen the fixing nut on the cover of the air filter case (9) to remove the cover (Fig. 15).

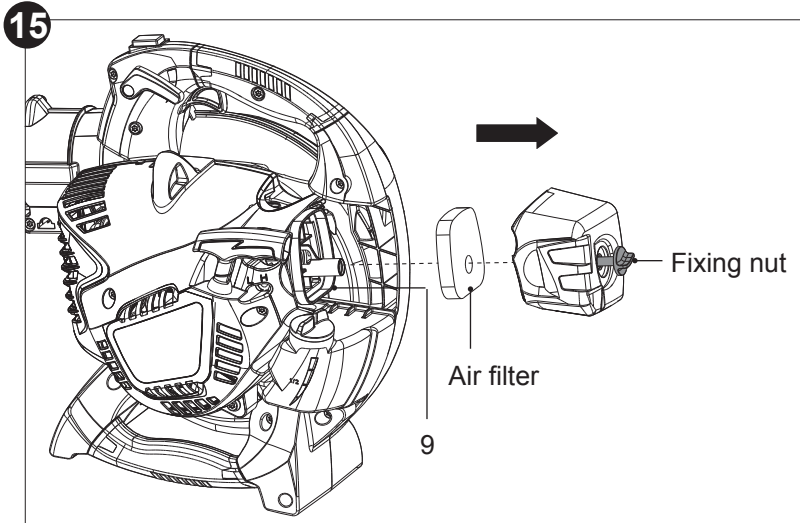

2. Remove the air filter and tap it on a stable surface to remove dust. Use compressed air (max. 3 bar) to remove stubborn dust.
3. Apply a small amount of air filter oil on the air filter to obtain an optimal performance. Wring out surplus oil and put the air filter into the case.
4. Refit the air filter. Refit the cover and secure it with the fixing nut.

### Fuel, fuel lines and fuel filter

The fuel tank of this machine is fitted with a filter located at the free end of the fuel pipe. If it is necessary to clean or replace the fuel filter, contact an authorised service centre or a similarly qualified person.

- > Keep fuel fresh (less than 30 days) or add fuel stabiliser.
- > Empty the fuel tank after every use.
- > Run the machine dry of fuel in idle before storage.
- > Replace fuel lines and fuel filters every 2 years.

## Spark plug



**NOTE:** For good performance, the spark plug must be properly gapped and free of deposits.

Inspect the spark plug every 25 hours or before long-term storage over 30 days. Clean or replace with a new one if necessary (type: NGK BPMR7A).

1. Disconnect the spark plug connector (6) on the top of the main unit (Fig. 16).

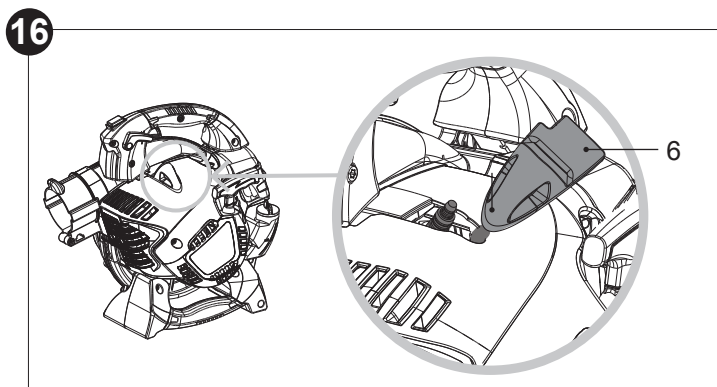

2. Loosen the spark plug anti-clockwise using the multi-tool (20) and remove it carefully (Fig. 17).

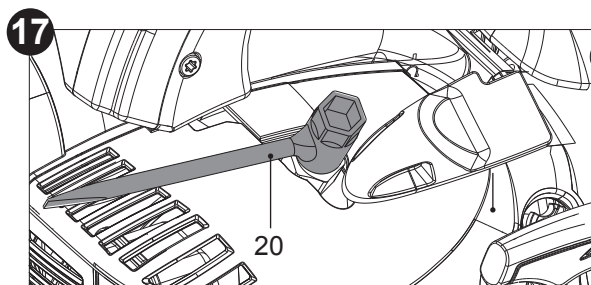

3. Check the spark plug for damage and wear. The colour of the ground electrode should be light-brown.
4. Remove the deposits from the electrode with a soft wired brush. Avoid heavy cleaning of the electrode.
5. Dry the spark plug with a soft cloth, if it is wet from fuel.

6. Check the spark plug gap. It should be **0.6-0.7 mm** (Fig. 18).

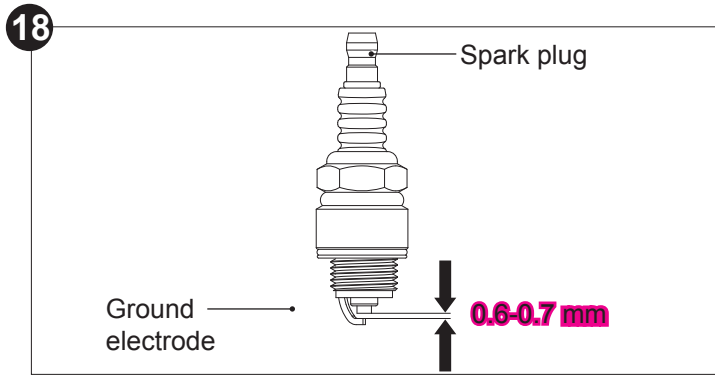

7. Replace with a new spark plug if either the electrode or the insulation is damaged.  
 8. When replacing the spark plug, first screw it in hand tight and then lightly tighten it with the multi-tool (20).



**NOTE:** Do not over tighten the spark plug to avoid any damage!

9. Refit the spark plug connector (6).

### Carburetor

The carburetor has been carefully set at the factory. Adjustment may be necessary if you notice that the engine does not idle (e.g. the engine stalls when the throttle trigger (4) is released). Contact an authorised service centre or dealer to do idle speed adjustment.



**WARNING!** Keep others away when making idle speed adjustment. Keep the nozzle off the ground and ensure that it does not contact with any object. The engine will be running during this procedure. Wear personal protective equipment and observe all safety precautions.

1. Release the throttle trigger (4) and allow the engine to idle.
2. Turn the idle speed screw clockwise using the screwdriver (22) to increase engine speed if engine stalls or dies in idle mode (Fig. 19).
3. Turn idle speed screw anticlockwise using the screwdriver (22) to decrease engine speed.

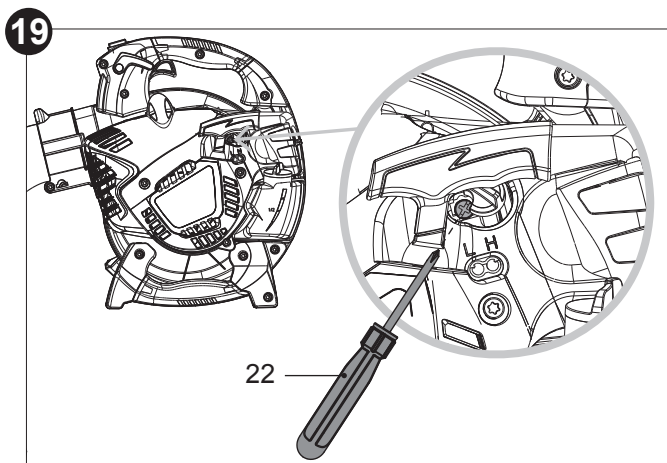

**WARNING!** Adjusting the screws L and H must be performed by an authorised service centre or a similarly qualified person. Using a pac man screwdriver (not provided) turn the screws L and H to adjust the quantity of fuel in relation to the air.

### Muffler

If it be necessary to modify the muffler, contact an authorised service centre or a similarly qualified person.

## Spare parts/Replacement parts

The following parts of this machine may be replaced by the consumer. Spare parts are available at an authorised dealer or through our customer service.

Description	Model no. or Specification
Spark plug	NGK BPMR7A (Gap of electrodes: <b>0.6-0.7 mm</b> ) or other model with same specifications

## Maintenance

Inspect and maintain this machine regularly based on below maintenance table. Keep the chain saw in good working condition during maintenance.

Part	Task	Before/after each use	Every 10 hours of operation	Every 25 hours of operation
Spark plug	check			X
	clean			X
	replace		whenever necessary	
Air filter	check	X		
	clean		X	
	replace		whenever necessary	
Fuel filter	clean		whenever necessary	
	replace		whenever necessary or every 2 years	
Tube/ nozzles	check	X		
	clean	X		

## Repair

This machine does not contain any parts that can be repaired by the consumer. Contact an authorised service centre or a similarly qualified specialist to have it checked and repaired.

## Storage



**WARNING! Risk of injury!** Make sure that unauthorized persons do not have access to the machine!



**NOTE:** Good storage conditions are important for keeping your machine trouble-free.

1. Clean the machine as described above.
2. Attach transportation guards, if applicable.
3. Store the machine and its accessories in a dry, frost-free, well-ventilated place.
4. Always store the machine in a place that is inaccessible to children. The ideal storage temperature is between 10 and 30 °C.
5. Store the machine in its bag or cover it with a suitable cloth to protect it against dust.

### Short term storage (less than 1 day)

1. Let the machine cool down before storage.
2. Store the machine as horizontally as possible. Make sure that no fuel-oil mixture can run out of the carburettor.

## Long term storage



### NOTE: Risk of machine damage!

- > If you are not going to use the machine for a while, remove the fuel from the machine. This way, you will prevent a gumming-up of the engine and of the grease pump.
- > Store the machine in a dry place and far away from possible sources of ignition such as ovens, gas thermostats, etc.

1. Empty the fuel tank (11) if you are not going to use the machine for an extended period of time (more than 3 months) and before storing it for the winter.
2. Start the engine and let it run until the engine stops by itself (see “Starting the engine”).
3. Let the engine cool down (approx. 5 min).
4. Disconnect the spark plug connector (6) and remove the spark plug.
5. Let a teaspoon of clean two-stroke engine oil run into the combustion chamber.
6. Pull the recoil starter handle slowly several times in order to coat the internal components with the oil.
7. Refit only the spark plug and leave the spark plug connector (6) disconnected.

## Transportation

1. Stop the engine and disconnect the spark plug connector (6) before transporting it anywhere.
2. Attach transportation guards, if applicable.
3. Always carry the machine by its handle.
4. Protect the machine from any heavy impact or strong vibrations which may occur during transportation in vehicles.
5. Secure the machine to prevent it from slipping or falling over, loss of fuel, damage and injury.

### If you are transporting the machine in a vehicle:

- > Let the machine cool down.
- > Empty fuel tank (11).
- > Secure the machine against slipping using bungee cords (not provided) and vehicle's transportation hooks.

## Troubleshooting

Suspected malfunctions are often due to causes that the operators can fix themselves. Therefore check the machine using this section. In most cases, the problem can be solved quickly.



**WARNING!** Only perform the steps described in these instructions! All further inspection, maintenance and repair work must be performed by an authorised service centre or a similarly qualified specialist if you cannot solve the problem yourself!

Engine does not start	Tank empty?	Fill the fuel tank.
	Incorrect starting procedure?	Follow the engine starting procedure.
	Spark plug connector not firmly attached?	Attach the spark plug connector firmly.
	Spark plug is wet?	Dry the spark plug.
	Spark plug connector is dirty?	Clean the spark plug connector.
	Excess fuel in the combustion chamber?	Set the choke to OPEN position and pull the recoil starter handle several times. If the engine does not start: remove spark plug and dry off electrode.
	Spark plug is soiled (tip is rusted)?	Clean or replace the spark plug.
	Primer has not been pressed at cold start?	Press the primer 6 times and restart. Follow the engine starting procedure.
	Primer has been pressed at warm start?	The engine (carburetor) has been flooded with fuel. Wait for few minutes to let the fuel drain before trying again.
	Gap between electrodes is too large?	Set gap between electrodes between <b>0.6-0.7 mm.</b>
Incorrect fuel or incorrect mixture?	Stop the engine, empty tank, then fill up with the correct mixture of fuel to oil (40:1).	



<b>Problem</b>	<b>Possible cause</b>	<b>Solution</b>
Engine does not reach the maximum speed.	Air filter is soiled?	Clean the air filter.
	Incorrect fuel or incorrect mixture?	Stop the engine, empty tank, then fill up with the correct mixture of fuel to oil (40:1).
	Carburetor setting not correct?	Have a qualified person adjust the carburetor.
Excessive vibration/ noise or smoke.	Incorrect fuel or incorrect mixture?	Stop the engine, empty tank, then fill up with the correct mixture of fuel to oil (40:1).
	Loosen fasteners on the machine?	Stop the engine and re-tighten the loosened fasteners.
Poor blowing performance.	Tube/nozzles blocked?	Stop the engine and remove blockage.

## Recycling and disposal

1. Old equipments are potentially recyclable and do not, therefore, belong in your household rubbish. You are requested to assist us and our contribution to saving resources and protecting the environment by handing in this equipment to an equipped collection centre (if there is one available).
2. Petrol, oil, used oil, a mixture of oil and petrol and objects soiled with oil e.g. cleaning cloths do not belong in the household rubbish. Dispose of oil-contaminated items in accordance with the local guidelines and hand them in at recycling centres.
3. The equipment comes in a package that protects it against damage during shipping. Keep the package until you are sure that all parts have been delivered and the equipment is operating properly. Recycle the package afterwards.

## Guarantee

We take special care to select high quality materials and use manufacturing techniques that allow us to create products incorporating design and durability. This product has a manufacturer's guarantee of 3 years against manufacturing defects, from the date of purchase (if bought in store) or date of delivery (if bought online), at no additional cost for normal (non-professional or commercial) household use.

To make a claim under this guarantee, you must present your proof of purchase (such as a sales receipt, purchase invoice or other evidence admissible under applicable law), please keep your proof of purchase in a safe place. For this guarantee to apply, the product you purchased must be new, it will not apply to second hand or display products. Unless stated otherwise by applicable law, any replacement product issued under this guarantee will only be guaranteed until expiry of the original period guarantee period.

This guarantee covers product failures and malfunctions provided the product was used for the purpose for which it is intended and subject to installation, cleaning, care and maintenance in accordance with the information contained in these terms and conditions, in the user manual and standard practice, provided that standard practice does not conflict with the user manual.

This guarantee does not cover defects and damage caused by normal wear and tear or damage that could be the result of improper use, faulty installation or assembly, neglect, accident, misuse, or modification of the product. Unless stated otherwise by applicable law, this guarantee will not cover, in any case, ancillary costs (shipping, movement, costs of uninstalling and reinstalling, labour etc), or direct and indirect damage.

Rights under this guarantee are enforceable in the country in which you purchased this product. Guarantee related queries should be addressed to the store you purchased this product from.

The guarantee is in addition to and does not affect your statutory rights.





This guarantee does not affect your statutory rights.

## Customer care and technical helpline

### A better way to repair your tools

Kingfisher takes special care in creating high-quality garden power tools that are designed to last. But if a fault develops with your garden power tool and you need to claim under the guarantee, the Customer Care and Technical Helpline can support with technical assistance or if required, arrange a free courier collection from your home, assess your garden power tool for fault, repair it, and return it.

Deciding to repair your product rather than buying a replacement and adding to the mountain of waste is a more sustainable choice and you will be doing your bit for the environment.

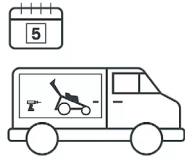
How does it work?				
				
<b>Step 1</b> Find your proof of purchase and get in touch with the Customer Care and Technical Helpline.	<b>Step 2</b> Chat to them about the problem with your tool.	<b>Step 3</b> They will provide technical and user advice or alternatively arrange a courier collection from your home*.	<b>Step 4</b> The team will access and test and if necessary, repair your product back to full working order.	<b>Step 5</b> Your repaired tool will be returned to you via courier within 5 working days.



\* **NOTE:** Before collection, all fuel must be removed from petrol powered machines.

### Get in touch

If you need help or more information, please contact the Customer Care and Technical Helpline:

UK: 0800 0789647

EIRE: 1800 932226

Opening hours are Monday – Friday, 8am-5pm

---

## Availability of spare parts

---

Contact the customer service helpline for assistance or visit [www.kingfisherspares.com](http://www.kingfisherspares.com)

For assistance contact the customer services helpline:

UK: 0800 0789647 [uk@kingfisherservice.com](mailto:uk@kingfisherservice.com)

EIRE: 1800 932226 [eire@kingfisherservice.com](mailto:eire@kingfisherservice.com)

Further information about this product can also be found at:

[www.kingfisher.com/products](http://www.kingfisher.com/products)

# UK CA

## (UK) DECLARATION OF CONFORMITY

### Product

- > Petrol Blower
- > EBP28
- > 27.6 cm<sup>3</sup>, 0.8 kW/ 8300 min<sup>-1</sup>
- > 000001 - 999999

### Name and address of the manufacturer or his authorised representative:

Kingfisher International Products Limited  
3 Sheldon Square  
London W2 6PX  
United Kingdom

This declaration of conformity is issued under the sole responsibility of the manufacturer.

### Object of the declaration

Product	Model	EAN
Petrol Blower	EBP28	5059340256375

The object of the declaration described above is in conformity with the relevant legislation:

Supply of Machinery (Safety) Regulations 2008 as amended  
Noise Emission in the Environment by Equipment for Use Outdoors Regulations 2001 as amended  
Electromagnetic Compatibility Regulations 2016 as amended  
The Restriction of the use of Certain Hazardous Substances in Electrical and Electronic Equipment Regulations 2012 as amended

Measured Sound Power Level: 106.6 dB(A)  
Guaranteed Sound Power Level: 109 dB(A)

Engine Model: 1E35F

References to the relevant designated standards used or references to the other technical specifications in relation to which conformity is declared:

EN 15503:2009/A2:2015  
EN ISO 14982:2009

Authorised signatory and technical file holder:  
Kingfisher International Products Limited  
3 Sheldon Square  
London W2 6PX  
United Kingdom



David Awe  
Group Quality & Sustainability Director  
On: 07/03/2022



(EN) EU DECLARATION OF CONFORMITY  
 (FR) DÉCLARATION UE DE CONFORMITÉ  
 (PL) DEKLARACJA ZGODNOŚCI UE  
 (RO) DECLARAȚIA DE CONFORMITATE UE  
 (ES) DECLARACIÓN UE DE CONFORMIDAD  
 (PT) DECLARAÇÃO DE CONFORMIDADE UE

Machine/Produit/Produkt/Produsul/Machineo/Produto

> Petrol Blower/ **Petrol Blower/ Petrol Blower/ Petrol Blower/ Petrol Blower/ Petrol Blower**  
 > EBP28  
 > 27.6 cm<sup>3</sup>, 0.8 kW/ 8300 min<sup>-1</sup>  
 > 000001 - 999999

Name and address of the manufacturer or his authorised representative:

Nom et adresse du fabricant ou de son mandataire:

Nazwa i adres producenta lub jego upoważnionego przedstawiciela:

Denumirea și adresa producătorului sau a reprezentantului său autorizat:

Nombre y dirección del fabricante o de su representante autorizado:

Nome e endereço do fabricante ou do respetivo mandatário:

Kingfisher International Machines B.V.,  
 Rapenburgerstraat 175E,  
 1011 VM Amsterdam,  
 The Netherlands  
[www.kingfisher.com/machines](http://www.kingfisher.com/machines)

This declaration of conformity is issued under the sole responsibility of the manufacturer.

La présente déclaration de conformité est établie sous la seule responsabilité du fabricant.

Niniejsza deklaracja zgodności wydana zostaje na wyłączną odpowiedzialność producenta.

Prezenta declarație de conformitate este emisă pe răspunderea exclusivă a producătorului.

La presente declaración de conformidad se expide bajo la exclusiva responsabilidad del fabricante.

A presente declaração de conformidade é emitida sob a exclusiva responsabilidade do fabricante.

Object of the declaration/Objet de la declaration/Przedmiot deklaracji/Obiectul declarației/Objeto de la declaración/Objeto da declaração

**Machine/Produit/Produkt/Produsul/Machineo/Produto**

**Model/Modèle/  
Model/Modelul/  
Modelo/ Modelo**

**EAN**

> Petrol Blower/ **Petrol Blower/ Petrol Blower/ Petrol Blower/ Petrol Blower/ Petrol Blower**

EBP28

5059340256375

The object of the declaration described above is in conformity with the relevant Union harmonisation legislation:

L'objet de la déclaration décrit ci-dessus est conforme à la législation d'harmonisation de l'Union applicable:

Wymieniony powyżej przedmiot niniejszej deklaracji jest zgodny z odpowiednimi wymaganiami unijnego prawodawstwa harmonizacyjnego:

Obiectul declarației descris mai sus este în conformitate cu legislația relevantă de armonizare a Uniunii: El objeto de la declaración descrita anteriormente es conforme con la legislación de armonización pertinente de la Unión:

O objeto da declaração acima descrito está em conformidade com a legislação de harmonização da União aplicável:

2006/42/EC as amended	Machinery Directive
2014/30/EU as amended	Directive Electromagnetic compatibility
2000/14/EC as amended	Outdoor Noise Directive
2016/1628/EU Regulation	Gaseous and Particulate Pollutant Emission Limits
2011/65/EU as amended	Directive Restriction of the use of certain hazardous substances in electrical and electronic equipment
2006/42/CE en tant que directive modifiée	sur les machines
2014/30 / UE telle que modifiée	Directive Compatibilit�e �lectromagn�tique
2000/14/CE en tant que directive modifiée	sur le bruit ext�rieur
2016/1628/R�glement de l'UE	Limites d'�mission de gaz et de particules
Directive 2011/65 / UE telle que modifiée	Limitation de l'utilisation de certaines substances dangereuses dans les �quipements �lectriques et �lectroniques
2006/42/WE w zmienionej dyrektywie	maszynowej
2014/30 / UE ze zmianami	Dyrektywa Kompatybilno�c �lektromagnetyczna
2000/14/WE w zmienionej dyrektywie	w sprawie ha�asu na zewn�trz
2016/1628/UE limity emisji	zanieczyszcze� gazowych i cz�stek stałych
2011/65 / UE ze zmianami	Dyrektywa Ograniczenie stosowania niekt�rych niebezpiecznych substancji w sprz�cie elektrycznym i elektronicznym
2006/42/CE, astfel a fost modificat�	Directiva privind echipamentele
2014/30/UE, astfel a fost modificat�	Directiva privind compatibilitatea electromagnetic�
2000/14/CE, astfel a fost modificat�	Directiva privind zgomotul �n aer liber
2016/1628/UE Regulamentul privind emisiile	de poluanți gazeoși și de particule poluante
2011/65/UE, astfel a fost modificat�	Directiva privind limitarea utiliz�rii anumitor substanțe periculoase �n echipamentele electrice și electronice
Directiva sobre maquinaria modificada	2006/42/CE
2014/30/UE modificada	Directiva Compatibilitad electromagn�tica
2000/14/CE modificada	Directiva sobre ruido al aire libre
2016/1628/Reglamento de la UE	Limites de emisiones de contaminantes gaseosos y part�culas
2011/65/UE modificada	Directiva Restricci�n del uso de determinadas sustancias peligrosas en equipos el�ctricos y electr�nicos
2006/42/CE como diretiva de m�quinas	alteradas
2014/30/UE como altera��o da compatibilidade	eletromagn�tic
2000/14/CE como diretiva de ru�do exterior	alterada
Limites de emiss�o de poluentes gasosos e de poluentes de part�culas	2016/1628/REGULAMENTO da UE
2011/65/UE como restri��o diretiva alterada da utiliza��o de certas subst�ncias	perigosas em equipamentos el�tricos e eletr�nicos

Measured Sound Power Level/ Le niveau de puissance acoustique mesuré/ Zmierzony poziom mocy akustycznej/ Nivel de putere acustică măsurat/ Nivel de potencia sonora medido / Nivel de potência sonora medido: 106.6 dB(A)

Guaranteed Sound Power Level/ Le niveau de puissance acoustique garanti/ Gwarantowany poziom mocy akustycznej/ Nivel de putere acustică garantat/ Nivel de potencia sonora garantizado/ Nivel de potência sonora garantido: 109 dB (A)

Engine Model/ Modèle de moteur/ Model silnika/ Modelul motorului/ Modelo de motor/ Modelo de motor: 1E35F

References to the relevant harmonised standards used or references to the other technical specifications in relation to which conformity is declared:

Références des normes harmonisées pertinentes appliquées, y compris la date de celles-ci, ou des autres spécifications techniques, y compris la date de celles-ci, par rapport auxquelles la conformité est déclarée:

Odwolania do odnośnych norm zharmonizowanych, które zastosowano, wraz z datą normy, lub do innych specyfikacji technicznych, wraz z datą specyfikacji, w odniesieniu do których deklarowana jest zgodność:

Trimiteri la standardele armonizate relevante folosite, inclusiv data standardului, sau trimiteri la celelalte specificații tehnice, inclusiv data specificațiilor, în legătură cu care se declară conformitatea:

Referencias a las normas armonizadas pertinentes utilizadas, incluidas las fechas de las normas, o referencias a las otras especificaciones técnicas, incluidas las fechas de las especificaciones, respecto a las cuales se declara la conformidad:

Referências às normas harmonizadas aplicáveis utilizadas, incluindo a data da norma, ou às outras especificações técnicas, incluindo a data da especificação, em relação às quais é declarada a conformidade:

EN 15503:2009/A2:2015

EN ISO 14982:2009

Authorised signatory and technical file holder/signataire et responsable de la documentation technique autorisé/ podmiot uprawniony do wystawienia i adres przechowywania dokumentacji technicznej/semnatar autorizat și deținător al dosarului tehnic/firmante autorizado y titular del expediente técnico/ signatário autorizado e detentor da ficha técnica

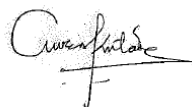

David Awe  
Group Quality & Sustainability Director  
On/le/dnia/la/am/el/em: 07/03/2022

Kingfisher International Products B.V.,  
Rapenburgerstraat 175E,  
1011 VM Amsterdam, The Netherlands



# Erbauer®

**Manufacturer, Fabricant, Prodecent,  
Producător, Fabricante:**

**UK Manufacturer:**

Kingfisher International Products Limited  
3 Sheldon Square London W2 6PX  
United Kingdom

**EU Manufacturer:**

Kingfisher International Products B.V.  
Rapenburgerstraat 175E 1011 VM Amsterdam  
The Netherlands



[www.diy.com](http://www.diy.com)  
[www.screwfix.com](http://www.screwfix.com)  
[www.screwfix.ie](http://www.screwfix.ie)

To view instruction manuals online,  
visit [www.kingfisher.com/products](http://www.kingfisher.com/products)